

ALUMINIUM HOOKS & CONNECTORS / MOUSQUETONS ALUMINIUM

Ref: FA 50 103 22

Aluminium Screw-locking Karabiner

Mousqueton aluminium à verrouillage à vis



EN362:2004	
Class A	
Class B	✓
Class Q	
Class T	

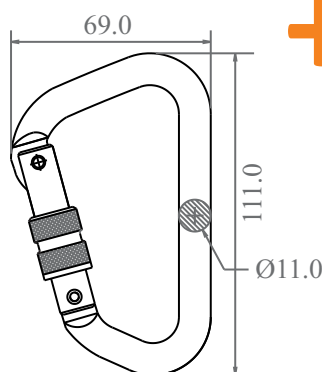
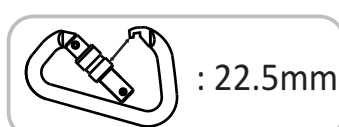

Ref:
FA 50 103 22 B

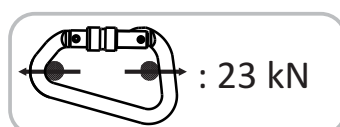

Keylock Version
Version Keylock